

MODEL 6127 MASTERSYNC VIDEO MONITOR

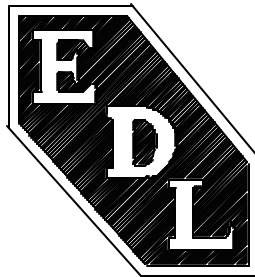

OPERATION AND MAINTENANCE MANUAL

**EDL Displays, Inc.
1300 Research Park Drive
Dayton, Ohio 45432
(937) 429-7423
www.edldisplays.com**

REVISED: June 20, 2000

TABLE OF CONTENTS

INTRODUCTION	1
GENERAL INFORMATION	2
VIDEO BANDWIDTH	2
AUTOMATIC SYNC ADAPTATION	2
EASE OF ADJUSTMENT	2
RELIABILITY	2
MODULAR CONSTRUCTION	2
CONFIGURATION CONTROL	2
MAINTAINABILITY	3
LOOP THRU OPERATION	3
SPECIFICATIONS	4
DEFLECTION	4
POWER REQUIREMENT	4
CRT	5
VIDEO	5
USER ADJUSTMENTS	6
PHYSICAL AND ENVIRONMENTAL	6
OTHER FEATURES	7
WARRANTY	7
MANUAL	7
INSTALLATION	8
GENERAL	8
UNPACKING	8
AC POWER CONNECTION	8

MECHANICAL INSTALLATION	8
SIGNAL INPUT CONNECTIONS	11
OPERATION	13
CALIBRATION PROCEDURES	15
VERTICAL SIZE ADJUSTMENT	15
HORIZONTAL POSITION ADJUSTMENT	15
HORIZONTAL SIZE ADJUSTMENT	15
TRAPEZOID ADJUSTMENT	16
PINCUSHION ADJUSTMENT	16
HORIZONTAL LINEARITY	16
TILT	16
REMOTE CONTROL OPERATION	18
MICROPROCESSOR BOARD LIGHT AND DIP SWITCH DEFINITIONS	21
LIGHT DEFINITIONS	21
DIP SWITCH SETTING DEFINITIONS	21
MAINTENANCE, ADJUSTMENTS AND TROUBLESHOOTING	22
FAULT ISOLATION/TROUBLESHOOTING	22
MAINTAINABILITY	22
REPLACEABLE ITEMS	23
ORGANIZATIONAL LEVEL TROUBLESHOOTING	23
VIDEO AMPLIFIER BOARD REPLACEMENT	25
DEFLECTION BOARD REPLACEMENT	26
MICROPROCESSOR BOARD REPLACEMENT	27
LOW VOLTAGE POWER SUPPLY REPLACEMENT	28
VERTICAL DEFLECTION BOARD REPLACEMENT	29
HIGH VOLTAGE POWER SUPPLY REPLACEMENT	30
HIGH VOLTAGE POWER SUPPLY ALIGNMENT PROCEDURE	31
ANODE AND G2 VOLTAGE ADJUSTMENT PROCEDURE	32

FOCUS VOLTAGE ADJUSTMENT PROCEDURE	33
CATHODE RAY TUBE REPLACEMENT	34
APPENDIX A	36
LIST OF ACRONYMS	36

LIST OF ILLUSTRATIONS

FIGURE 1 MODEL 6127 OUTLINE DRAWING.....	9
FIGURE 2: 110/220 SWITCH LOCATION.....	10
FIGURE 3: 6127 REAR PANEL SIGNAL INPUT CONNECTIONS.....	12
FIGURE 4: CALIBRATION FLOW CHART.....	17
FIGURE 5: ORGANIZATIONAL LEVEL TROUBLESHOOTING FLOWCHART.....	24

LIST OF TABLES

TABLE 1: CONTROL FUNCTIONS IN OPERATIONAL AND CALIBRATE MODE.....	14
TABLE 2: LIST OF ORGANIZATIONAL LEVEL REPLACEABLE ITEMS.....	23

INTRODUCTION

This technical manual contains operation and maintenance instructions for the **EDL Model 6127 MasterSync Video Monitor**. This model is a high quality, high performance, high-resolution monitor. All EDL Displays, Inc. products are unique in their ability to automatically synchronize, store and display virtually any video format. This feature makes it very useful in communications applications.

This manual should be carefully reviewed before attempting operation. A thorough understanding of the control functions is required for proper set -up and operation of the monitor.

To achieve the best results from this model, please follow the procedures in the order given below:

1. Review the Operation and Maintenance Manual.
2. Determine the operating system format and the system signal input cabling required. Follow the guide in this manual when attaching system input cabling.
3. If customized calibration is required, follow the calibration procedures in this manual.

When corresponding with EDL Displays relative to this equipment, please include the Model Number and Serial Number of the monitor in question.

GENERAL INFORMATION

VERY HIGH RESOLUTION

The dynamically focus cathode ray tubes provide for sharp images up to and including 1600 x 1280.

VIDEO BANDWIDTH

The video bandwidth of 140MHz supports resolutions up to 1600 x 1280 @ 60 Hz NI.

AUTOMATIC SYNC ADAPTATION

These monitors will automatically sync and display any RGB video format within its operating frequency range. It will automatically accommodate five (5), four (4), and three (3) cable signal formats in that order of priority.

EASE OF ADJUSTMENT

Most controls that may be necessary to adjust in the field are accessible either at the front or rear panel. Additional adjustments are available via an optional wired remote.

RELIABILITY

The monitor is designed with reliability as paramount in importance. Reliability is accomplished by using high quality parts and assuring that these parts are operating at less than their intended stress levels. Large devices, which must dissipate heat, are mounted on the rear panel heat sinks.

MODULAR CONSTRUCTION

The monitor is all metal construction around a card cage configuration. All circuitry is on rear panel plug-in modules.

CONFIGURATION CONTROL

Any changes to the monitor design are form, fit, and function to previous revisions. The replaceable modules in the units delivered today are backward compatible into the first EDL Displays product shipped in January 1990. EDL Displays, Inc. retains records of all monitors shipped and any unique customer requirements.

MAINTAINABILITY

All circuitry within the monitor is contained in functional replaceable modules such as deflection output, microprocessor control, video amplifier, and power supplies. A defective module can be detected by simple tests and the monitor can be repaired by replacing the module. This may eliminate the need for a field service representative or shipment of the monitor back to the factory.

An important benefit of these plug-in replaceable modules is the very short Mean-Time-To-Repair (MTTR).

Since the replaceable modules are the same as used in other EDL Displays products, sparing and personnel training are greatly simplified.

LOOP THRU OPERATION

Loop thru operation is provided by a HI-LO impedance switch selection. This allows the use of the monitor with other devices on the output of the video driver or video switch.

SPECIFICATIONS

EDL MODEL 6127 MASTERSYNC MONITOR SPECIFICATIONS

DEFLECTION

SCAN RATE RANGES: Horizontal scan rates from 15 to 100 kHz, 40 to 120 Hz non-interlaced and 20-60 Hz interlaced vertical. Automatic selection to match input video format.

RETRACE TIME: Maximum of 3.0 microseconds horizontal and 400 microseconds vertical.

HORIZONTAL AND VERTICAL SYNC: Automatic detection and selection of composite (3 wire), separate video and mixed sync (4 wire), and separate video, vertical and horizontal sync (5 wire). *Polarity:* Negative only for three wire operation. The sync signals may be positive or negative for four and five wire operation. Separate sync inputs are TTL compatible 1.0 to 4.0 volts peak to peak.

LINEARITY: Horizontal and vertical non-linearity (when measured using the EIA Standard Ball Chart Method or equivalent) is less than $\pm 1\%$ raster height.

RASTER SIZE REGULATION: Raster size change caused by changes in CRT beam current from 0-100% APL (approximately 0 to 200 Microamps) will be less than 0.5%.

GEOMETRIC DISTORTION: No point on the raster (i.e., pixel) is displaced from its proper position by more than 1% of raster height within an 11 inch circle and no more than 1.5% elsewhere.

POWER REQUIREMENT

AC POWER: Input voltage 90-132 VAC or 180-264 VAC switch selectable inside the monitor, 47 to 63 Hz. Power consumption is 150 Watts maximum.

CRT

SCREEN SIZE AND TYPE: 29-inch (27-inch viewable) diagonal, 0.37mm dot pitch DAF gun, burst protection, 90-degree deflection with P22 short persistence color phosphor. The 52% transmissivity anti-glare filter is integral to the flat-square screen.

WARM UP TIME: A maximum of 5 minutes for the monitor to meet the specifications contained herein.

RESOLUTION AND DISPLAY SIZE: The Model 6127 has 1600 X 1280 resolution with a maximum display area of 21.29" (541mm.) wide by 15.97" (406mm.) high.

VIDEO

BRIGHTNESS: Nominal 21 foot-Lamberts.

FREQUENCY AND PULSE RESPONSE (20 fL):

Bandwidth @ -3.0 dB;	1.0Hz to 140 MHz
Flatness @ ± 0.5 dB;	10HZ to 120 MHz
Rise/Fall Time:	3.0 nsec

SIGNAL INPUT IMPEDANCE:

Resistance @ Low-Z:	75 OHM \pm 5%
Resistance @ High-Z:	> 20k OHM
Capacitance:	8 pF (nominal) @ 2 MHz

SIGNAL INPUT LEVEL (AC COUPLED):

Composite:	1.0 Vp-p Nominal (0.7 - 1.4 Vp-p)
Non-Composite:	0.7 Vp-p Nominal (0.5 - 1.0 Vp-p)

SYNC SIGNAL (COMPOSITE ON GREEN):

Back Porch:	1.2 uSec minimum
Level:	0.3 Vp-p Nominal (0.2-0.4 Vp-p)
Width:	1.0 uSec Nominal (0.5-3.0 uSec)
Polarity:	Negative

SYNC INPUT:

Separate or mixed:	1.0 to 4.0 V p-p nominal - positive or negative polarity.
--------------------	--

SYNC TIMING REQUIREMENT:

HORIZONTAL Sync Pulse	≥ 1.0 u s
--------------------------	----------------

Back Porch	$\geq 1.2 \text{ u s}$
Front Porch	≥ 0
VERTICAL	
Sync Pulse	$\geq 25 \text{ u s}$
Back Porch	$\geq 375 \text{ u s}$
Front Porch	≥ 0

DC OUTPUT RESTORER (BLANKING):

Stability	Black level within 1% of peak luminance at any APL from 10% to 90%.
Range:	+60 V to +0765 V (Adjustable)

INPUT CONNECTIONS: Coaxial BNC with selectable 75 OHM or high impedance termination.

USER ADJUSTMENTS

EXTERNAL: RGB Video - Gain and black level.

CALIBRATION MODE: Front panel adjustment for all minor alignment needs including: vertical position, vertical size, horizontal position, horizontal size, trapezoid, pincushion, horizontal linearity, and picture tilt for a minimum of sixteen different video formats.

PHYSICAL AND ENVIRONMENTAL

MECHANICAL: Rugged metal chassis construction with rear panel accessible functional modules. Like modules are interchangeable from unit to unit.

TEMPERATURE: 0 to 50 degrees centigrade operating; -40 to +85 degrees centigrade non-operating.

HUMIDITY: 5 - 95 percent non-condensing.

ALTITUDE: 3000 meters (10,000 ft) operating and 13,000 meters (30,000 ft) non-operating.

DIMENSIONS: Overall 25" wide by 21" high by 25.75" deep.

WEIGHT: 130 lbs (59 Kgs.).

CAUTION! These monitors are awkward and require two people for safe handling.

OTHER FEATURES

MASTER SYNC: Automatic detection and alignment to a maximum of sixteen different video formats. The video formats may have totally different timing specifications. All format values are stored in non-volatile memory.

DEGAUSS: Automatic deGauss at power on with manual deGauss switch provided on front. Minimum time between deGauss operations is ten minutes.

SWEEP FAILURE DETECTION: High voltage disabled with either horizontal or vertical sweep loss.

CONTROLS: Power on/off, Contrast/Calibration, Brightness and Mode provided on front of the monitor.

WARRANTY

One year parts and labor at EDL Displays, Inc.

MANUAL

One copy supplied with each unit includes:

- Installation
- Operation
- Maintenance

INSTALLATION

GENERAL

This section describes the installation of the monitor. The monitor is pre-aligned at the factory to user input requirements. However, there may still be the need for some minor adjustments to be made. Those procedures will be provided later in the Calibration Procedures section.

UNPACKING

Before unpacking, the carton should be inspected for shipping damage. The carton should be carefully opened and the monitor removed. The monitor should then be carefully inspected for shipping damage. If damage has occurred, the shipping carton and all packing materials should be saved for possible inspection by the shipping company. The shipping company and EDL Displays should be notified at this time.

AC POWER CONNECTION

Before connecting the monitor, determine what AC power is to be used and make sure that the monitor is configured properly for that voltage. **NOTE:** The power setting upon shipment is 110 volts unless otherwise requested by the customer. The voltage of the monitor may be changed at the power supply module accessible from the rear of the unit. The power supply must be removed for access to the voltage select switch (see figure 2).

MECHANICAL INSTALLATION

The 6127 monitor is designed to be mounted and secured in place on any flat surface.

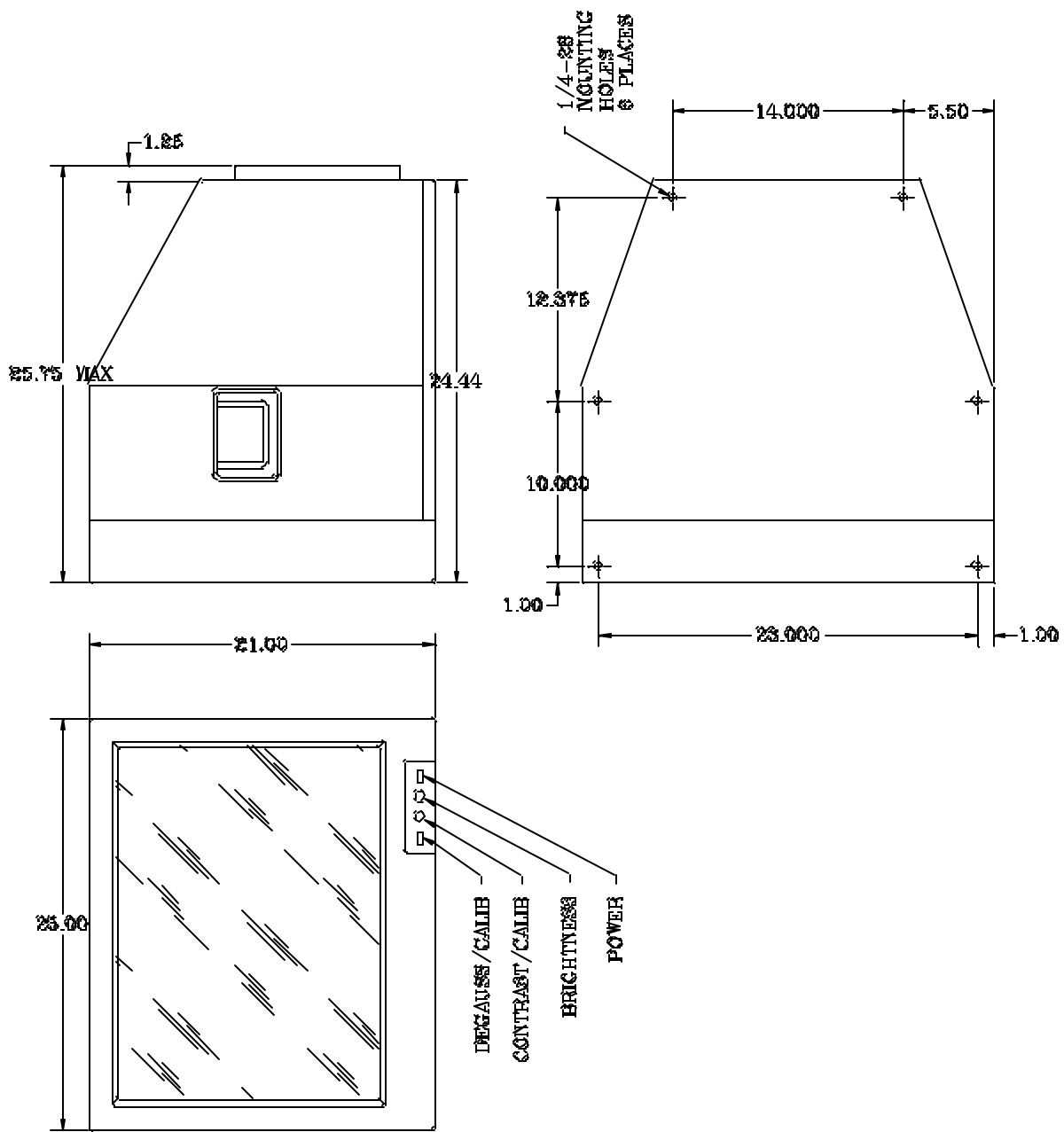

Figure 1 Model 6127 Outline Drawing

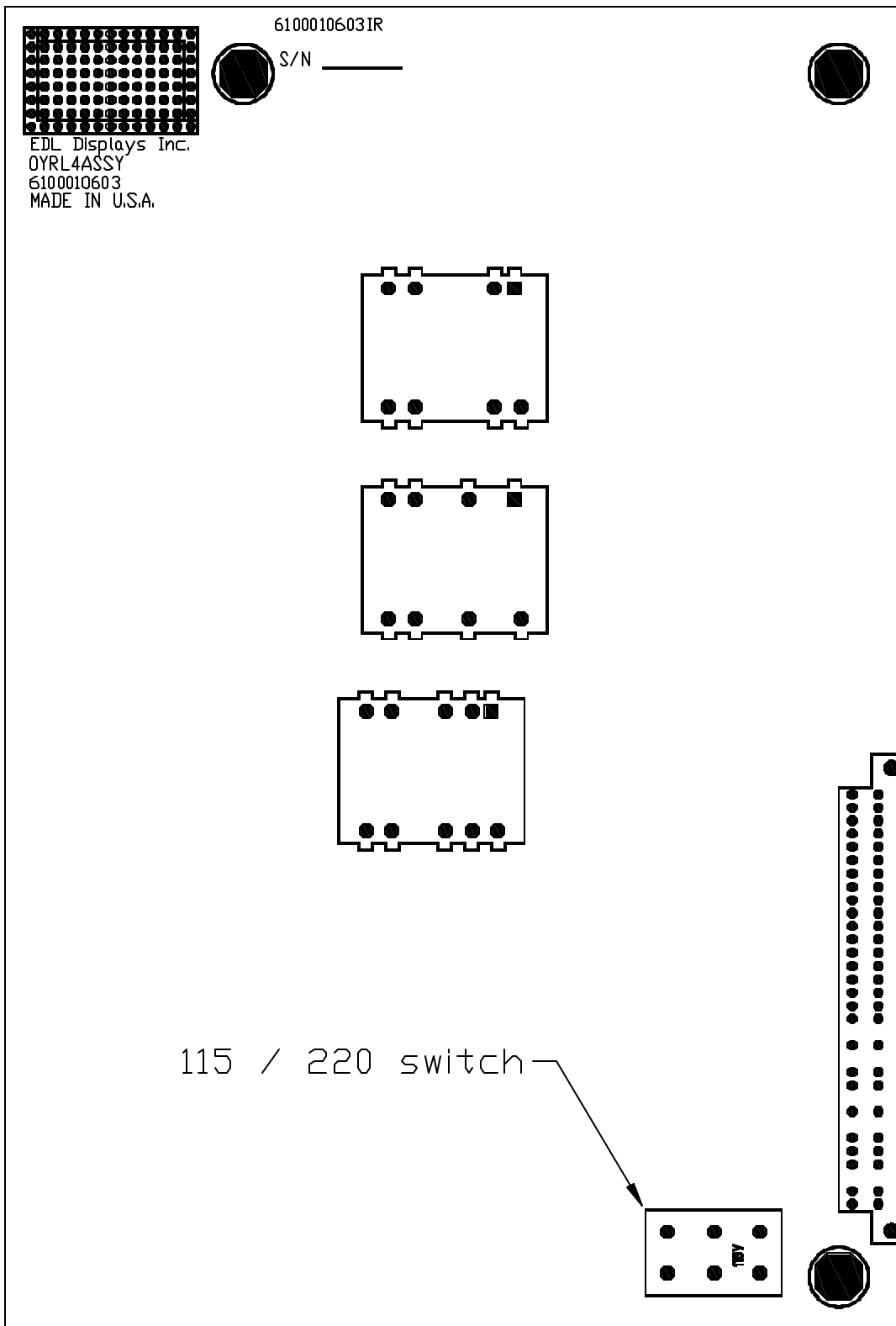

Figure 2: LVPS 110/220 Switch Location

SIGNAL INPUT CONNECTIONS

See Figure 3 for location of rear panel signal input connections.

The Model 6127 Master Sync Monitor will automatically adapt to the user's synchronization system format. Three formats are supported. These are:

1. RGB video signal with composite sync on green video signal.
2. RGB video signal with separate mixed sync signal.
3. RGB video signal with separate vertical and horizontal sync signals.

The video inputs may be adjusted to accommodate from 0.7 to 1.4 volts peak to peak video signal levels. Any d.c. offset on the signal is eliminated by AC coupling and d.c. restoration at the video amplifier during the back porch portion of the video signal.

The external sync inputs can accommodate from 1.0 to 4.0 volts peak to peak signals without any adjustments. These inputs are AC coupled and d.c. restored by the monitor before thresholding occurs. The sync inputs may be either positive or negative polarity and need not be the same polarity.

All signal inputs may be switched from 75 Ohm to high impedance (20 kilOhm) for "loop-thru" operation. User-supplied BNC "T" adapters must be used to connect the additional devices between the raster engine and the final device on the line. Because of the very high performance of the devices involved, extreme care must be taken by following these guidelines.

1. The graphics driver must be at the beginning of the transmission line. BNC "T" adapters must not be used at the raster engine.
2. All devices must be set for high impedance input except for the last device on the transmission line.
3. The last device on the transmission line **MUST have a 75 Ohm** termination impedance and not have BNC "T" adapters at its connectors unless used for the terminators.
4. All cables **MUST be 75 Ohm** impedance and as short as possible (for most signal sources cable length should not exceed 10 feet).

NOTE: These aforementioned rules are not unique to this monitor. They must be followed to assure proper operation of these high performance devices regardless of their manufacture.

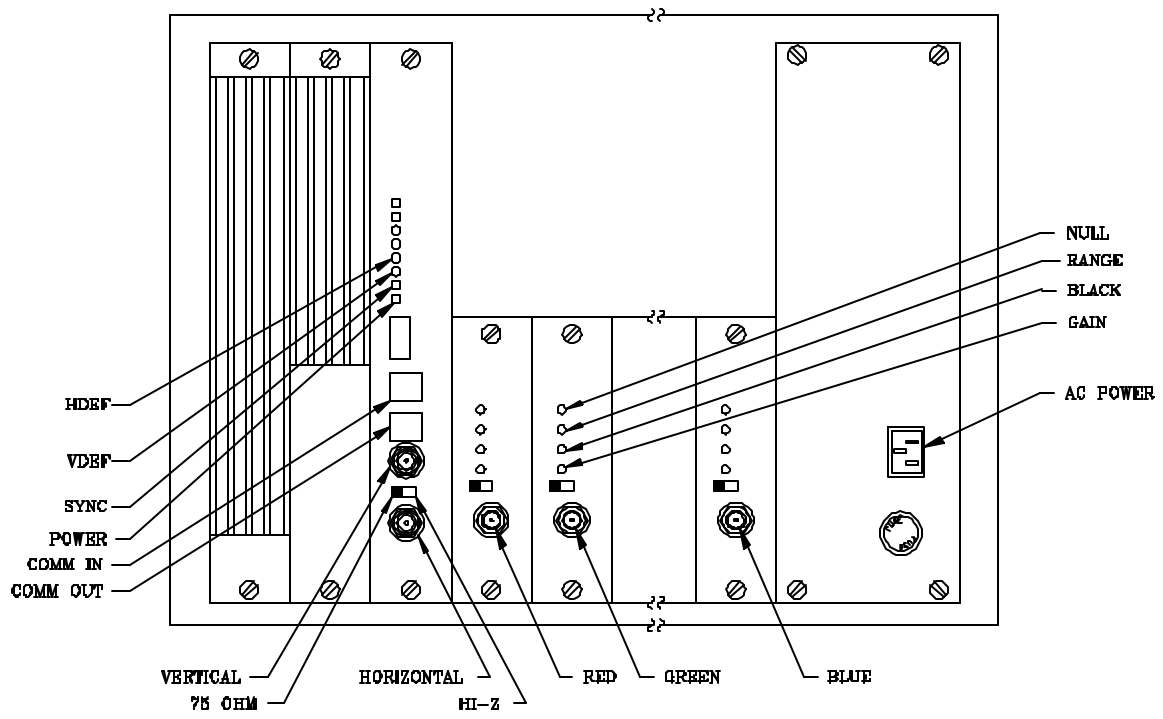

Figure 3: 6127 Rear Panel Signal Input Connections

OPERATION

The method of operation of the Model 6127 is similar to ordinary monitors with respect to power, brightness, contrast and deGauss. However, they do have an additional mode called "Calibrate". The "Calibrate" mode permits the user to program an internal microprocessor to memorize alignment parameters for the user video formats.

Two of the front panel controls have a dual function. Table 1 is a summary of the front panel controls and their functions in the "Operational" and "Calibrate" modes.

The front panel controls include:

1. ON/OFF
2. BRIGHTNESS
3. CONTRAST
4. DEG/CAL

CONTROL NAME	OPERATIONAL MODE	CALIBRATE MODE
<p align="center">ON/OFF (Alternate Action)</p>	<p>1. Controls primary AC power to the monitor.</p>	<p>Same as Operational</p>
<p align="center">BRIGHTNESS (Rotary Potentiometer)</p>	<p>1. Adjusts background (or Black Level) relative to the operating environment.</p>	<p>Same as Operational</p>
<p align="center">CONTRAST (Dual function, Rotary Potentiometer)</p>	<p>1. Adjust Gain of video Amplifiers</p>	<p>Establishes custom memory values for:</p> <ol style="list-style-type: none"> 1. Vertical Position 2. Vertical Size 3. Horizontal Position 4. Horizontal Size 5. Horizontal Pincushion 6. Horizontal Trapezoid 7. Horizontal Linearity 8. Tilt <p>Must be performed in this sequence.</p>
<p align="center">DEG/CAL (Dual Function Momentary Switch)</p>	<ol style="list-style-type: none"> 1. Monitor performs deGauss when momentarily pressed. 2. Monitor enters calibrate mode when pressed and released for (>5 sec.) 	<ol style="list-style-type: none"> 1. Initiates Entry into and Exit from Calibrate mode. 2. Steps the monitor through a programmed sequence of sub modes.

Table 1: CONTROL FUNCTIONS IN OPERATIONAL AND CALIBRATE MODE

CALIBRATION PROCEDURES

CAUTION

DO NOT REMOVE OR INSERT MODULES OR SUB-ASSEMBLIES WITH POWER APPLIED. DOING SO MAY RESULT IN EXTENSIVE DAMAGE TO ELECTRICAL COMPONENTS.

NOTES:

Apply power and input signals and allow the monitor to warm up for five minutes.

When the monitor is placed in the Calibrate Mode, a definite programmed sequence of calibration steps must be followed. Refer to Table 1 and Figure 4 for the sequence.

To enter the calibration mode, press and hold the **DEG/CAL** button for five seconds.

While in the Calibrate Mode, you can back up one step by holding the **DEG/CAL** button down for three seconds.

VERTICAL POSITION ADJUSTMENT

Adjust the vertical position by rotating the **CONTRAST** control slowly until the control "locks on" and then set the desired position.

To advance to the vertical size adjustment mode, press and release the **DEG/CAL** switch.

VERTICAL SIZE ADJUSTMENT

Adjust the vertical size by rotating the **CONTRAST** control slowly until the control "locks on" and then set the vertical size as desired.

To advance to the horizontal position adjustment mode, press and release the **DEG/CAL** switch.

HORIZONTAL POSITION ADJUSTMENT

Adjust the horizontal position by rotating the **CONTRAST** control slowly until the control "locks on" and then set the desired horizontal position.

To advance to the horizontal size adjustment mode, press and release the **DEG/CAL** switch.

HORIZONTAL SIZE ADJUSTMENT

Adjust the horizontal size by rotating the **CONTRAST** control slowly until the control "locks on" and then set the horizontal size to the desired value.

To advance to the trapezoid adjustment mode, press and release the **DEG/CAL** switch.

PINCUSHION ADJUSTMENT

Make the pincushion adjustment by rotating the **CONTRAST** control slowly until the control "locks on" and then set the control to eliminate any pincushion effect.

To advance to the horizontal linearity adjustment mode, press and release the **DEG/CAL** switch.

TRAPEZOID ADJUSTMENT

Make the trapezoid adjustment by rotating the **CONTRAST** control slowly until the control "locks on" and then set the control to eliminate the trapezoidal effect.

To advance to the pincushion adjustment mode, press and release the **DEG/CAL** switch.

HORIZONTAL LINEARITY

Make the horizontal linearity adjustment by rotating the **CONTRAST** control slowly until the control "locks on" and then set the control to so the left side of the screen is the same size as the right side of the screen.

To advance to the tilt adjustment mode, press and release the **DEG/CAL** switch.

TILT

Make the tilt adjustment by rotating the **CONTRAST** control slowly until the control "locks on" and then set the control to eliminate any tilt in the screen.

To exit the calibration mode, press and release the **DEG/CAL** switch.

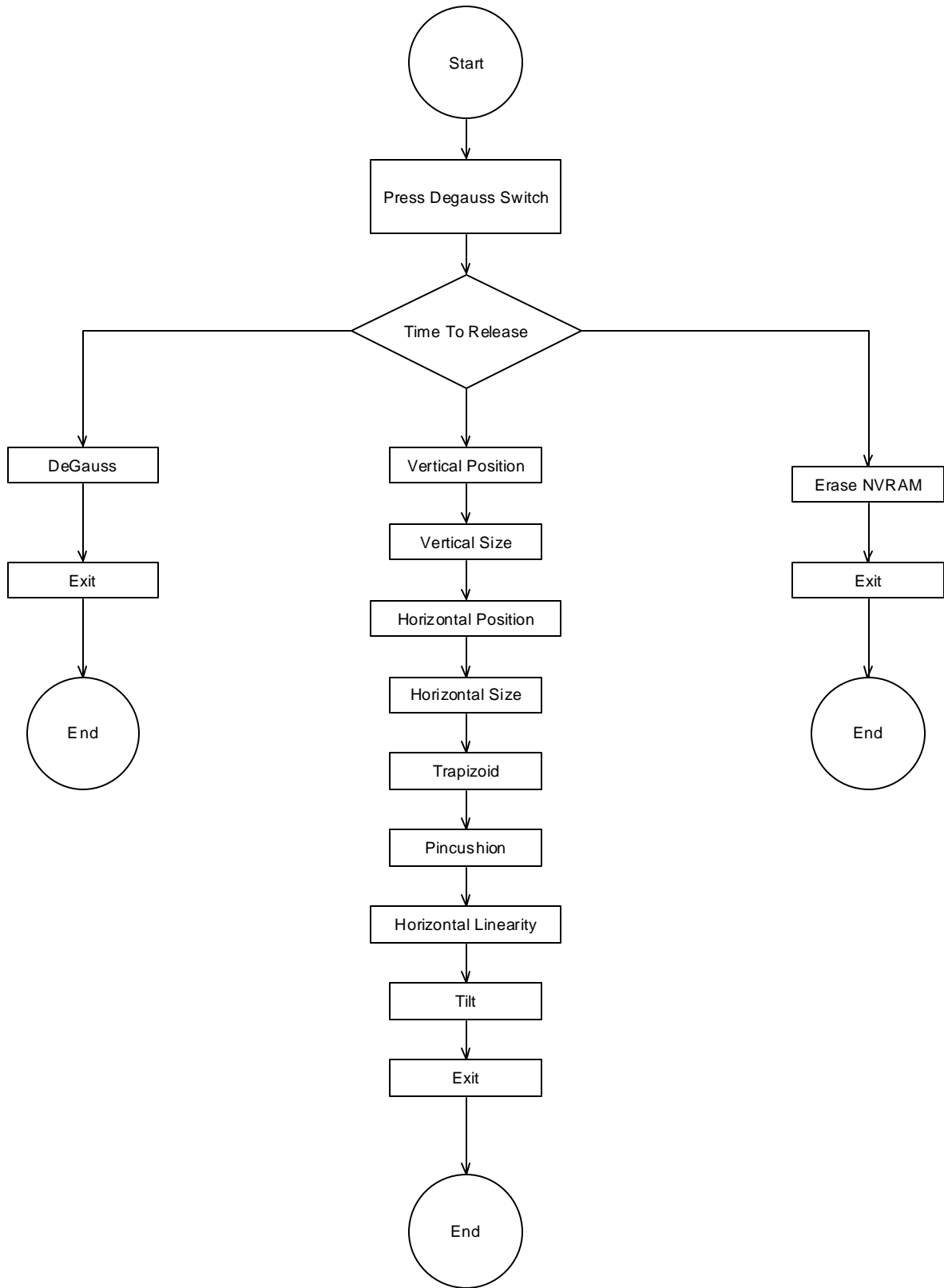

Figure 4: Calibration Flow Chart

REMOTE CONTROL OPERATION

Adjustments to the monitor may be made from the monitor remote control. The remote control includes a membrane keypad with a Liquid Crystal Display (LCD). The remote control panel provides monitor select, color balance, geometry and control level information all on the LCD. Monitor adjustment parameters are detailed in Table 1. To enter adjustment mode press the key of the monitor desired (in single monitor systems this is #1). Then press the key of the desired adjustment. Press the large up and down arrows for coarse adjustments and the small arrows for fine adjustments. The results of the adjustments are stored in temporary memory until they are saved in non-volatile memory by pressing F2 from the main menu.

















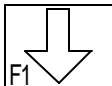
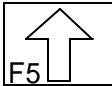
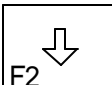
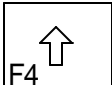
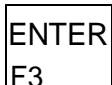



F1 ↓	F2 ↓	ENTER F3 ↑	F4 ↑	F5 ↑
1	2	3	4	5
6	7	8	9	10
V-SIZE	V-POS	VERT RETRACE	H-SIZE	H-POS
		V-PIN SHAPE		
VERT FOCUS				HORZ FOCUS
V CONV STAT	H CONV MAG	H CONV PHASE	H CONV STAT	H FOCUS SHAPE
ALL GAIN	R GAIN	G GAIN	B GAIN	DEFAULT
ALL BLACK	R BLACK	G BLACK	B BLACK	CTRL
MAINT	STATUS SLEEP	DE- GAUSS	ENTER	SHIFT

Figure 1 Hand-Held Remote Control Keypad

Remote Adjustment Controls

KEY(S)	FUNCTION										
 	Course adjustment of selected function; decrease or increase										
 	Fine adjustment of selected function; decrease or increase. “F2” function also saves all parameters in monitor memory.										
	Enters the selected value in temporary memory and returns display to selection menu.										
<table border="1" style="display: inline-table; border-collapse: collapse;"> <tr> <td style="text-align: center;">1</td> <td style="text-align: center;">2</td> <td style="text-align: center;">3</td> <td style="text-align: center;">4</td> <td style="text-align: center;">5</td> </tr> <tr> <td style="text-align: center;">6</td> <td style="text-align: center;">7</td> <td style="text-align: center;">8</td> <td style="text-align: center;">9</td> <td style="text-align: center;">10</td> </tr> </table>	1	2	3	4	5	6	7	8	9	10	Monitor select buttons. Default value is 1 through 5; 6 through 10 may be selected using the “Shift” key.
1	2	3	4	5							
6	7	8	9	10							
 	Adjusts vertical screen size (from top down) and vertical position.										
 	Adjusts horizontal screen size and horizontal position.										
	Adjusts compression of horizontal lines in the top half of the screen. Minor effect.										
	Affects the flatness of the top horizontal line.										
	“VPIN_MAG” bows all horizontal lines but the center out or in.										
	“VPIN_CENT” bows all horizontal lines (including center) up or down.										
	“VPIN_PHASE” slants all horizontal lines but the center away/toward each other.										
	“HPIN” barrels or pincushions (bows) all vertical lines but the center.										
	“HTRAP” slants all vertical lines but the center away/toward each other.										
	“TILT” rotates the screen clockwise or counter-clockwise about the center.										
	“HTILT” slants all vertical lines relative to horizontal lines.										

<div style="display: flex; justify-content: space-around;"> <div style="border: 1px solid black; padding: 2px; text-align: center;">VERT FOCUS</div> <div style="border: 1px solid black; padding: 2px; text-align: center;">HORZ FOCUS</div> </div>	Vertical focus adjusts focus from center to top; horizontal focus from center to sides.
<div style="border: 1px solid black; padding: 2px; text-align: center;">H FOCUS SHAPE</div>	Equalizes focus on left and right sides of the screen.
<div style="border: 1px solid black; padding: 2px; text-align: center;">V CONV STAT</div>	Adjusts the overall convergence of the <i>horizontal</i> R,G,B lines.
<div style="border: 1px solid black; padding: 2px; text-align: center;">H CONV MAG</div>	Adjusts the R,G,B convergence of the center <i>vertical</i> lines relative to outer lines.
<div style="border: 1px solid black; padding: 2px; text-align: center;">H CONV PHASE</div>	Adjusts the R,G,B convergence of the left edge <i>vertical</i> lines relative to the right.
<div style="border: 1px solid black; padding: 2px; text-align: center;">H CONV STAT</div>	Adjusts the overall R,G,B convergence of <i>vertical</i> lines across the entire screen.
<div style="display: flex; justify-content: space-around; text-align: center;"> <div style="border: 1px solid black; padding: 2px;">ALL GAIN</div> <div style="border: 1px solid black; padding: 2px;">R GAIN</div> <div style="border: 1px solid black; padding: 2px;">G GAIN</div> <div style="border: 1px solid black; padding: 2px;">B GAIN</div> </div>	Adjusts gain/contrast level of all colors (“ALL”) or each individual color.
<div style="display: flex; justify-content: space-around; text-align: center;"> <div style="border: 1px solid black; padding: 2px;">ALL BLACK</div> <div style="border: 1px solid black; padding: 2px;">R BLACK</div> <div style="border: 1px solid black; padding: 2px;">G BLACK</div> <div style="border: 1px solid black; padding: 2px;">B BLACK</div> </div>	Adjusts brightness/black level of all colors (“ALL”) or each individual color.
<div style="border: 1px solid black; padding: 2px; text-align: center;">MAINT</div>	Enters the maintenance mode of the monitor. <i>For EDL technicians only.</i>
<div style="border: 1px solid black; padding: 2px; text-align: center;">DE- GAUSS</div>	Energizes the coil around the monitor tube to demagnetize the screen.
<div style="border: 1px solid black; padding: 2px; text-align: center;">ENTER</div>	Mimics the function of the “ENTER/F3” button at the top center of remote.
<div style="border: 1px solid black; padding: 2px; text-align: center;">SHIFT</div>	Allows for selection of monitors # 6-10.
<div style="display: flex; justify-content: space-around;"> <div style="border: 1px solid black; padding: 2px; text-align: center;">DEFAULT</div> <div style="border: 1px solid black; padding: 2px; text-align: center;">CTRL</div> <div style="border: 1px solid black; padding: 2px; text-align: center;">STATUS SLEEP</div> </div>	Nonfunctional; reserved for future use.

MICROPROCESSOR BOARD LIGHT AND DIP SWITCH DEFINITIONS

LIGHT DEFINITIONS

Light	Meaning (When On)
1	None
2	None
3	None
4	None
H	H DEFL ON
V	V DEFL ON
SYNC	SYNC ON
PWR	POWER ON

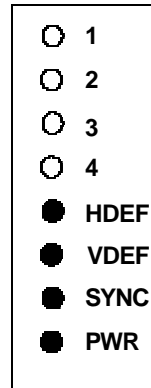

DIP SWITCH SETTING DEFINITIONS

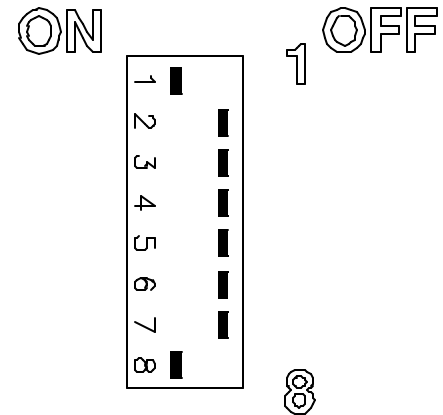

Switch	Label	Function
1	None	Monitor Address - 1
2	None	Monitor Address - 2
3	None	Monitor Address - 4
4	None	Monitor Address - 8
5	ERASEMEM	HI = Erase MEMORY at Power On
6	ENACALBUT	LO = Enable Front Panel Controls
7	ENAHREN	LO = Enable Horizontal Defl.
8	ENREM	HI = Remote power & indicators

MAINTENANCE, ADJUSTMENTS AND TROUBLESHOOTING

FAULT ISOLATION/TROUBLESHOOTING

Most problems in the Model 6127 video monitors can be isolated to a single module or pair of modules by careful observation and interpretation of the display presentation, the LEDs on the rear panel and various mechanical items. Generally, most problems are manifested by either a display presentation, which is incorrect or no display at all. By referring to a troubleshooting flow diagram, an experienced technician should be able to make an effective repair. The following procedure assumes that there is only one problem and not a situation compounded by multiple faults.

PROCEDURE:

1. Observe the display presentation and the fault indicators located on the Microprocessor Board (Switch 8 must be on for indicators to work).
2. Verify that all rear panel signal input coaxial BNC and AC power connections are correct and secure.
3. Verify that all front controls (**DEG/CAL**, **CONTRAST**, **BRIGHTNESS**, and **ON/OFF**) mechanically function properly and approximate their normal operating conditions.
4. Verify proper calibration before troubleshooting.
5. Using the observations in step 1, consult the troubleshooting flow diagram (FIG. 5) to isolate the problem to a module or modules.
6. **Remove power from unit.**
7. Replace the appropriate module or modules following the procedures given below for each module. As a precaution, both the monitor and the maintenance person should be grounded during any module replacement.

MAINTAINABILITY

All circuitry within the monitor is contained in functional replaceable modules such as deflection output, microprocessor control, video amplifiers (3), and power supplies. The maintenance described in this section is limited to on-line corrective maintenance requiring no special tools or test equipment. This maintenance will consist of isolating the fault to a particular module or pair of modules and then replacement of the defective module. Generally no calibration will be required after replacement of a defective module unless the Microprocessor Control Board is replaced.

REPLACEABLE ITEMS

Only the following items or modules are considered replaceable at the organizational level:

RI	RI DESCRIPTION	QTY	P/N
1	Video Amplifier Boards	3	6100-0305-03
2	Deflection Board	1	6100-0201-03
3	Microprocessor Board	1	6100-0102-03
4	Low Voltage Power Supply	1	6100-0106-03
5	High Voltage Power Supply	1	6100-0107-03
6	Vertical Deflection Board	1	6100-0112-03
7	F2-1.5A Buss Little Fuse GFA-1.5 251001	1	
8	F1-3A Buss Little Fuse MDV-3 315003	1	

Table 2: LIST OF ORGANIZATIONAL LEVEL REPLACEABLE ITEMS.

ORGANIZATIONAL LEVEL TROUBLESHOOTING

The Organizational Level Troubleshooting flow chart that follows assumes the following:

1. A signal source and signal cables are functioning properly.
2. Only one failure at a time.
3. Normal operation has the Microprocessor Board PWR, SYNC, VDEF, HDEF, lights lit and light "1" is flashing.

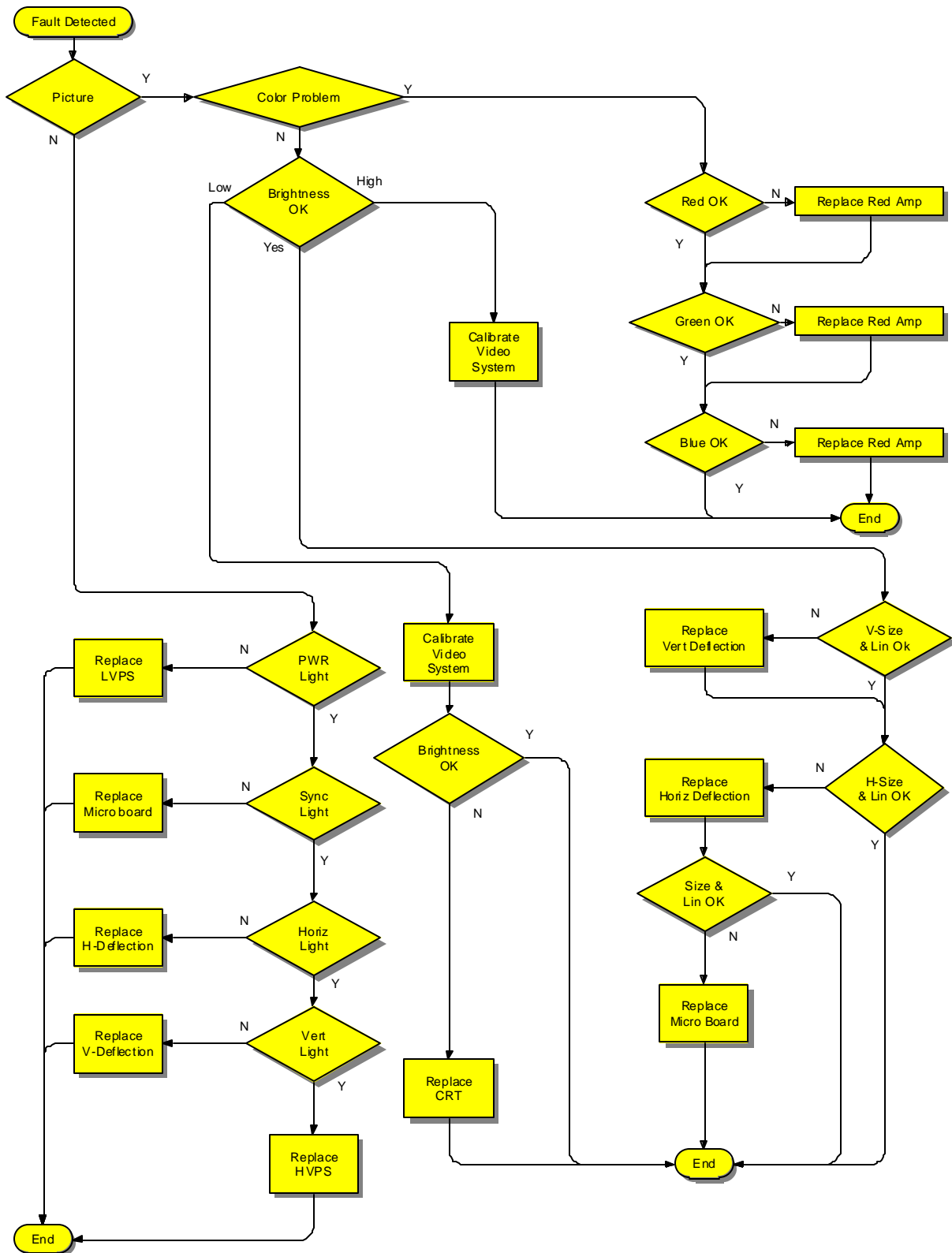

Figure 5: Organizational Level Troubleshooting Flowchart

VIDEO AMPLIFIER BOARD REPLACEMENT

P/N 6100-0305-03

Tools Required: 1. Screwdriver, common straight slot.
2. Adjustment tool, insulated 1/8" straight slot.

REPLACEMENT PROCEDURE

1. Turn AC power OFF at the front panel.
2. Disconnect the monitor AC power cord.
3. Disconnect the coaxial cable on the Video Amplifier Board being replaced.
4. Unscrew the two captive screws on the Video Amplifier Board.
5. Remove the Video Amplifier Board; inspect, as a precaution, the connector for bent pins, and inspect the mating connector on the Mother Board for damage.
6. Note the position of the adjustment pots in the defective Video Amplifier Board.
7. If the defective amplifier had been operating properly prior to the failure, then using a small screwdriver, position the Black and Gain adjustments in the replacement amplifier to match its counterpart in the defective amplifier. **CAUTION:** The Range and Null adjustments should **not** be changed except during the Video Amplifier Alignment Procedure.
8. Carefully insert the replacement Video Amplifier Board in its slot making sure the connector is properly aligned with the mating connector on the Mother Board.
9. Tighten the two captive screws to seat the module and complete the connection to the Mother Board.
10. Connect the coaxial input cable and AC power cord.
11. Apply AC power and input signals and check the display for proper operation.
12. Optimum picture quality may be attained by performing the Video Amplifier Alignment Procedure.

DEFLECTION BOARD REPLACEMENT

P/N 6100-0201-03

Tools Required: 1. Screwdriver, common, straight slot.

REPLACEMENT PROCEDURE

1. Turn AC power OFF at the front panel.
2. Disconnect the monitor AC power cord.
3. Unscrew the two captive screws on the Deflection Board.
4. Remove the Deflection Board from its slot. As a precaution, inspect the module connector and the Mother Board mating connector for damage.
5. Check and replace, if necessary, F1 (the 1 amp fuse), part number 251001. Retry Deflection Board. If the monitor remains inoperative, proceed to Step 6.
6. Carefully insert the replacement deflection module in its slot making sure the module connector is properly aligned with its mating connector on the Mother Board.
7. Tighten the two captive screws to seat the module and complete the connection to the Mother Board.
8. Connect the AC power cord.
9. Apply AC power and input signals and check the display for proper operation.

MICROPROCESSOR BOARD REPLACEMENT

P/N 6100-0102-03

Tools Required: 1. Screwdriver, common, straight slot.

REPLACEMENT PROCEDURE

1. Turn AC power OFF at front panel.
2. Disconnect the monitor AC power cord and the H&V BNC cables on the Logic Control Board.
3. Unscrew the two captive screws on the Logic Control Board.
4. Remove the Microprocessor Board from its slot. As a precaution, inspect the module connector and the Mother Board mating connector for damage.
5. Carefully insert the replacement Microprocessor Board into its slot making sure the connector is properly aligned with the mating connector on the Mother Board.
6. Tighten the two captive screws to seat the logic control board and complete the connection to the Mother Board.
7. Connect the H&V BNC cables to their appropriate connectors and connect the AC power cord.
8. Apply AC power and input signals and check the display for proper operation.

NOTE:

When the microprocessor module is replaced, all user programmed calibration parameters will need to be reestablished.

LOW VOLTAGE POWER SUPPLY REPLACEMENT

P/N 6100-0106-03

Tools Required: 1. Screwdriver, common, straight slot.

REPLACEMENT PROCEDURE

1. Turn AC power OFF at front panel.
2. Disconnect the monitor AC power cord.
3. Unscrew the four captive screws on the Low Voltage Power Supply (LVPS).
4. Remove the Low Voltage Power Supply from its slot; at this time, inspect the Power Supply Module connector for damage and check for blown fuses. Verify that the 115V/230V switch is set correctly. If there are any blown fuses, replace with the proper fuse and proceed to step 5. If the required AC input voltage is 115VAC. and the switch was set to the 230V AC position, set the switch to the required 115VAC. position and proceed to step 5. If the required voltage is 230VAC. and the switch was set to 115VAC. with power applied, Do Not Retry the Supply. Fuses: F1 -Buss Little Fuse MDV-3 315003, F2-1A Buss Little Fuse GFA-1 251001.

NOTE: Low Voltage Power Supply voltages are set at the factory - Do Not Adjust or attempt to adjust the voltage control pots. Check programmable dip-switch SW3 for proper setting.

<u>SW3-1</u>	<u>SW3-2</u>	<u>SW3-3</u>	<u>SW3-4</u>
OFF	ON	OFF	OFF

5. Carefully insert the Low Voltage Power Supply into its slot making sure the connector is properly aligned with the Mother Board mating connector. Check the following on the good supply before installing:
 - a. Good fuses in F1 & F2.
 - b. SW4 (115/230V AC switch) set for proper voltage (115V AC).
 - c. SW3 (B+/ext. control switch) set for multi-sync operation.
6. Tighten the four captive screws to seat the Low Voltage Power Supply.
7. Connect the AC power cord to the monitor.
8. Apply AC power and input signals and check the display for proper operation.
9. If a power supply has been re-tried after replacing a blown fuse or correcting a switch setting and the fault is not corrected, follow the above procedure and replace the Power Supply with a known good spare supply. If the fault still persists, submit the monitor to shop maintenance for evaluation.

VERTICAL DEFLECTION BOARD REPLACEMENT

P/N 6100-0112-03

Tools Required: 1. Screwdriver, common, straight slot.

REPLACEMENT PROCEDURE

1. Turn a/c. power OFF at the front panel.
2. Disconnect the monitor a/c. power cord.
3. Unscrew the two captive screws on the Vertical Deflection Board.
4. Remove the Vertical Deflection Board from its slot. As a precaution, inspect the module connector and the Mother Board mating connector for damage.
5. Carefully insert the replacement deflection module in its slot making sure the module connector is properly aligned with its mating connector on the Mother Board.
6. Tighten the two captive screws to seat the module and complete the connection to the Mother Board.
7. Connect the a/c. power cord.

Apply a/c. power and input signals and check the display for proper operation.

HIGH VOLTAGE POWER SUPPLY REPLACEMENT

P/N 6100-0107-03

- Tools Required:
1. Screwdriver, straight slot
 2. Screwdriver, Phillips #2
 3. Nut driver, 1/4"
 4. Insulated lead wire (No. 18-20ga.) 12-15 inches long with alligator clips on both ends.

Replacing the High Voltage Power Supply involves contact with dangerous high voltage elements. Follow instructions carefully and observe all safety precautions!

All efforts should be made to isolate the fault to the High Voltage Power Supply (HVPS) before beginning replacement.

Before replacing the HVPS, consider the following:

1. All BNC signal input connections on the rear panel have been checked for proper connection and the signal source is operating properly.
2. Front panel controls have not been inadvertently set to produce a no raster condition.
3. Microprocessor maintenance lights have been properly interpreted.
4. Low Voltage Power Supply (LVPS) has been replaced (the LVPS develops the input voltage for the HVPS).
5. When the monitor is turned on, there is normally a high voltage "crackle" sound as the high voltage builds up to 27 KV. If there is an audible "crackle" at turn on, the 27 KV is present.
6. If the monitor is functioning but out of focus, the HVPS focus control may need a simple adjustment. Refer to the High Voltage Power Supply Alignment Procedure.
7. The CRT filaments are visibly lighted through the top rear of the cabinet.

REPLACEMENT PROCEDURE

1. Turn AC power OFF at the front panel.
2. Disconnect the monitor AC power cord and all coaxial cables on the rear panel.
3. Wait twenty minutes for voltages to discharge.
4. Remove the top panel by removing all screws and clamping the panel vertically to the left side of the enclosure.

CAUTION! High lethal voltages could be present at the CRT anode - follow

procedure carefully.

5. Connect chassis to earth ground.
6. Attach one end of a 12-15 inch clip lead to the metal shaft of a screwdriver which has a well insulated handle. (Do not use wooden handle screwdrivers.)
7. Connect the other end of the clip lead to the metal chassis of the monitor such that the tip of the screwdriver can reach the HV anode lead on the CRT.
8. While holding only the insulated handle of the grounded screwdriver, carefully slide the tip of the metal blade under the rubber cover of the CRT anode lead and make contact with the metal electrode for at least five seconds. Repeat if necessary until arcing no longer occurs.
9. Remove the anode connection from the CRT.
10. Disconnect the focus lead.
11. Disconnect the HVPS power input connector at the HVPS.
12. Remove the four 6-32 nuts and washers on the mounting studs of the HVPS and remove the supply.
13. Install the new supply using the four washers and 6-32 nuts and tighten securely.
14. Connect the power input lead, focus lead, and the CRT anode connector. Make sure the anode lead rubber boot is securely in place and not damaged.
15. Check that all wiring and leads are properly dressed and that there is no conflict with screws, covers, etc.
16. Perform High Voltage Power Supply Alignment Procedure.
17. Replace top panel.
18. Connect all BNC signal cables and the AC power cable to the monitor.
19. Apply AC input power and input signals and check display for proper operation.

HIGH VOLTAGE POWER SUPPLY ALIGNMENT PROCEDURE

The Model 6127 High Voltage Power Supply has five output voltages of which four are adjustable.

1. 27,000 Volts (Anode Voltage)
2. 7,000 Volts (Focus 1 Voltage)
3. 7,000 Volts (Focus 2 Voltage)
4. 600 Volts (Grid 2 Voltage)
5. -200 Volts (Grid 1 Voltage)

The anode and G2 Voltages should be factory preset to their respective values. However, the

focus voltage must always be adjusted when either the CRT or the High Voltage Power Supply are replaced.

ANODE AND G2 VOLTAGE ADJUSTMENT PROCEDURE

EQUIPMENT REQUIRED:

1. Klein Instruments VPG250 or equivalent and cables.
2. FLUKE Model 27 Multi-meter with FLUKE 80K-40/1000 Meg-Ohm High Voltage Probe or equivalent.
3. 1/8 inch insulated flat point adjustment tool.

PROCEDURE:

1. This procedure requires removal of unit enclosure or top cover.
2. Connect the BNC cables from the video generator or test source.
3. Display a grid pattern if possible.
4. Connect the voltmeter negative lead to the monitor chassis. CAREFULLY slip the High Voltage Probe tip under the rubber insulator cap at the CRT anode connector.
5. If necessary, insert the adjustment tool in the small hole on the top of the High Voltage Power Supply near the power connector and adjust for a reading of 27 Volts (27,000 Volts Actual) on the multi-meter.
6. To adjust the G2 voltage, CAREFULLY insert the tip of the High Voltage Probe into pin 9 of the High Voltage Power Supply power connector. **Caution:** Ordinary voltmeter probes will result in inaccurate readings due to their loading.
7. If necessary, adjust the G2 potentiometer for a reading of +0.60 Volts (600 Volts Actual) on the multi-meter.
8. If the anode voltage required adjustment, it will be necessary to adjust the two focus voltages.

FOCUS VOLTAGE ADJUSTMENT PROCEDURE

EQUIPMENT REQUIRED:

1. Klein Instruments VPG250 or equivalent that provides single pixel line or character widths.
2. Insulated 1/4" straight screwdriver or adjustment tool.
3. BNC cables as required.

PROCEDURE:

1. This procedure requires removal of unit enclosure or top cover.
2. Connect the BNC cables from the video generator or test source.
3. Display a pattern such as dots or characters or grid pattern.
4. Observe "sharpness" of image at several locations on the screen.
5. Adjust Focus 1 for the best focus on vertical lines in the corners. Adjust Focus 2 for the best focus on horizontal lines near the center of the screen. It will be necessary to repeat this sequence until uniform focus is achieved.

CATHODE RAY TUBE REPLACEMENT

(P/N 6127-0108-03)

Tools Required:

1. Screwdriver, Phillips #2
2. Allen wrench, 3/16 inch
3. Insulated lead wire 15 inches long (18 to 20ga.) with clips on ends

All efforts should be made to isolate the fault to the Cathode Ray Tube (CRT) before beginning replacement.

CAUTION! Replacing the Cathode Ray Tube involves contact with dangerous high voltage elements. Follow instructions carefully and observe all safety precautions!

Before replacing the CRT consider the following:

1. All BNC signal input connections on the rear panel have been checked for proper connection and the signal source is operating properly.
2. Front panel controls have not been inadvertently set to produce a no-raster condition.
3. HV disable and SYNC indicators have been properly interpreted.
4. Low Voltage Power Supply (LVPS) has been replaced (the LVPS provides the input voltage for the HVPS).

REPLACEMENT PROCEDURE

CAUTION! Lethal Voltages could be present at the CRT connectors. Follow procedure carefully.

1. Turn Off a/c. power at the front panel.
2. Disconnect the monitor a/c. power cord and all five coaxial cables on the rear panel.
3. Wait twenty minutes for voltages to discharge.
4. Remove all rear panel plug-in modules.
5. Remove the rear enclosure by removing the 22 screws and lifting the cover off.
6. Connect the chassis to earth ground.
7. Attach one end of a clip lead to the metal chassis of the monitor such that the other end can reach the HV anode connector on the CRT.
8. Attach the other end of the clip lead to the metal shaft of the screwdriver.
9. While holding only the insulated handle of the grounded screwdriver, carefully slide the tip of the metal blade under the rubber cover of the CRT anode lead boot and make contact with the metal electrode for at least five seconds. Repeat if necessary until arcing no

longer occurs.

10. Remove the anode connection from the CRT.
11. Disconnect the CRT connector board from the CRT base connector.
12. Disconnect four pin Molex connector S8 (on end of Mother Board next to HVPS) and remove wires and pins from pins 1 and 2. This is accomplished by using a sharp object in the back of the connector body to release the pin to slide out.
13. Place monitor face down on table.
14. Remove the seven screws mounting the front bezel to the chassis.
15. Carefully remove the chassis back from bezel.
16. Once removed, the chassis will remain attached to the bezel by the front panel controls assembly. Remove the four screws securing the control assembly to the bezel with the Phillips screwdriver.
17. The four hex head screws mounting the CRT to the chassis should now be removed with a 3/16 inch Allen wrench. Lift the chassis away from the CRT taking care not to bump the neck of the CRT. The neck area is the most vulnerable area of the CRT.
18. Position the replacement CRT on its face plate on a soft surface.
19. If the CRT has the degauss coil already installed on the CRT body, proceed to the next step. If it does not, then attach the degauss coil from the old CRT to the new one with new pads and tie wraps. Super Glue is a good adhesive for this purpose.
20. Carefully position the CRT into the bezel and install the four Allen head mounting screws. Make sure the chassis and CRT are square with one another since this affects the alignment of the video image with the bezel.
21. Install the front panel control assembly to the bezel.
22. Install the chassis assembly onto the bezel assembly and secure with the seven Phillips head screw.
23. Place the monitor in an upright position.
24. Attach the CRT base connector assembly to the CRT.
25. Connect the anode lead to the CRT anode button on top the CRT.
26. Install the two degauss coil leads into four pin connector S8 with the white lead in pin 1.
27. Install the modules into the chassis.
28. At this time perform the VIDEO AMPLIFIER ALIGNMENT PROCEDURE contained in the Model 6127 Operation and Maintenance Manual.
29. Replace the rear cover and secure with 22 Phillips head screws.
1. Pat yourself on the back and take the rest of the day off.

APPENDIX A

LIST OF ACRONYMS

LVPS	Low Voltage Power Supply
HVPS	High Voltage Power Supply
CRT	Cathode Ray Tube
G1	Grid 1
G2	Grid 2
SYNC	Synchronization Pulse
RGB VIDEO	Red, Green & Blue Video